

Information Technology Improvement and Small Business Lending

Haiyan Pang¹

(Work in progress)

Abstract

This paper evaluates how information technology (IT) improvements contribute to the decline of small business lending in the US commercial banking market from 2002 to 2017. I estimate a general equilibrium dynamic model with banks that differ in sizes and choose the level of transaction (hard information intensive) and relationship (soft information intensive) lending. The model shows that banks' costs of evaluating borrowers' hard information declined over this period by 46%, and small business loans fell by 7% (12% in the data). I find that banks' higher reliance on IT to issue transaction loans is responsible for 37% of the decline in the data, and the consolidation caused by IT improvements caused 22% of the decline. Contrary to previous work, I find that when general equilibrium is considered, policy protecting small banks cannot increase small business lending.

Key words: Small business lending, relationship banking, banking consolidation, innovation, fin-tech

JEL classification: G20, G21

¹Ph.D. Candidate from the Department of Economics, Arizona State University. Contact Number: 480-878-9335. Email: Haiyan.Pang@asu.edu. Link to the latest version. I am grateful for the help and constructive advice from my committee members, Dan Silverman, Sreedhar Bharath and George Aragon, faculties from the Economics Department and Finance Department of Arizona State University, Alejandro Manelli, Basit Zafar, David Schreindorfer, Denis Sosyura, Esteban Aucejo, Galina Vereshchagina, Gustavo Ventura, Ilona Babenko, Jessie Wang, Luke Stein, Mark Seasholes, Michael Hertz, Natalia Kovrijnykh, Oliver Boguth, Yuri Tserlukevich, and people who discussed my paper at AFFI and EFMA conference. I am also indebted to Toni Whited who helped me on my estimation and Andrew Ellul, Baolian Wang and Rik Sen who helped me sharpen my ideas.

U.S. commercial banks have reduced loans to small businesses (defined as commercial and industrial [C&I] loans of less than \$1 million) by 12%, from \$340 billion to \$300 billion (measured in 2017 U.S. dollars) and small business loans as a share of total bank loans has declined from 6.7% to 3.5%, from 2002 to 2017. A decline in small business lending may generate important costs for the economy. Small businesses with fewer than 500 employees contributed to 62% of the net new jobs in the U.S. from 1992 to 2010². In 2017, more than 80% of small businesses saw bank credit as their major financing source, but only 53% of small business applicants were approved for all of the financing sought (the 2017 Small Business Credit Survey). The reallocation of bank loans from small to large firms may increase large firms' market power in local labor markets and thus, result in a decline of workers' wages (Azar, Marinescu and Steinbaum, 2017). As is suggested by Berger et al. (2005) and Stein (2002), this decline of small business lending may result from an increasing concentration in the US banking market, which comes from the improvement of information technology (Hayashi, Li and Wang, 2017; Sullivan and Wang, 2013). In addition, Liberti and Petersen (2017) suggest that information technology improvements may lower the evaluation costs of quantitative, objective hard information more than those of qualitative, subjective soft information. Thus, these improvements may have increased banks' advantage in hard-information intensive transaction lending to large corporations over soft-information intensive relationship lending to small businesses.

This paper evaluates the negative effects of information technology (IT) improvements on small business lending and what can be done to combat this trend if necessary. Three challenges lie in the identification. First, in the data, we cannot see the demand for small business loans and banks' willingness to lend to small business borrowers. Therefore, it is hard to establish casual effect between IT improvements and decline of lending to small businesses. Second, a bank's costs of IT is a choice variable for the bank as well as lending to small businesses. These two variables are probably affected by the same unobserved characters of the bank. For example, when a bank faces pressure from Stress Test, it may decrease lending to risky small business borrowers. Thus, the bank has lower information processing costs for a dollar of loans as banks have economy of scale in processing larger loans. Third, the decomposition of two mechanisms suggested will give quantitative answers to a question that has attracted much attention, but remains unsolved in the literature: to what degree, the consolidation has contributed to the decline of small business lending. As the consolidation may also be caused by IT improvements, it is not easy to quantify the

²The data are from <https://www.stlouisfed.org/publications/regional-economist/april-2011/are-small-businesses-the-biggest-producers-of-jobs>

contribution from the consolidation without a theory or an instrument variable. Because of these identification problems, I evaluate the effect from IT improvement on small business loans with a general equilibrium structural framework. This framework can also be used to evaluate policies that may encourage small business lending.

I build a dynamic model of relationship banking. In the model, I distinguish between relationship lending and transaction lending. Transaction lending is an “arm’s length” transaction based on hard information about a borrower. In comparison, relationship lending is based on a borrower’s hard information as well as soft information. As noted by Liberti and Petersen (2017), hard information is machine readable and quantifiable, but soft information is usually subjective, and its collection and evaluation are usually not separable and is expensive to collect. Therefore I assume that it is expensive for banks to build relationships with borrowers. Small business borrowers are modeled as risky borrowers. Small borrowers are risky for banks because of insufficient credit histories and low credit scores (according to the 2017 Small Business Credit Survey). For banks, lending to small borrowers is less profitable than lending to established businesses (Mills and McCarthy, 2016). However, a bank can improve the returns from these borrowers by monitoring their cash flow and restructuring delinquent loans promptly (Bolton et al., 2016). In the model, lending with additional monitoring through bank-borrower relationships is relationship lending. Consequently, risky small borrowers are more likely to receive relationship loans than transaction loans (Boot and Thakor, 2000)³. The dynamic features of the model are built on Hopenhayn (1992). In the model, banks decide to grow or exit according to the advancing rate of lending technology and the competition in the deposit market. The bank size distribution is thus endogenous to IT improvements.

The model suggests two mechanisms by which IT improvements can reduce the amount of small business lending: a substitution effect between transaction and relationship lending and a crowding-out effect between large and small banks. Liberti and Petersen (2017) find that IT improvements favor the collection of hard information over soft information. I assume therefore that the cost of acquiring hard information decreases, but that the acquisition of soft information is as expensive as before⁴. As a consequence, banks’ profits

³This assumption is a simplification of the reality. It does not mean that lending to large corporations requires no bank-borrower relationships at all. The conclusion in the model still holds as long as lending to small businesses more depends on bank-borrower relationships, which is suggested by Chodorow-Reich (2013).

⁴The assumption is a simplification of reality where the cost of acquiring hard information decreases faster than the cost of acquiring soft information. As is in Liberti and Petersen (2017), “Hard information is quantitative, easy to store and transmit in impersonal ways, and its information content is independent

from transaction lending increase more than those from relationship lending. Banks thus decrease the share of relationship loans in their portfolios. The second effect is the crowding-out effect, in which larger banks with smaller shares of small business lending gain market share. IT improvement increases the lending capacity of large banks more than that of small banks. IT improvement also intensifies competition in the deposit market and increases the cost of deposits. Small banks that face high costs of staying in the market will become less profitable and choose to exit. Overall, the share of small business lending declines. In both situations, if banks cannot increase their lending capacity enough, lending to small businesses falls.

I estimate the model with the U.S. individual commercial bank data from 2002 to 2007 and from 2012 to 2017⁵. I find that the technological advancements contribute to 58% of the small business decline in the US. I identify a set of parameters for which the simulated moments from the model are quantitatively consistent with the observed behavior of U.S. commercial banks. I use the moments of banks' total loans from 2002 to 2017 to identify the advancement rate of lending technology. From this identification, I link IT improvements to bank productivity growth. Using the share and amount of small business loans in 2002, I identify the parameters of banks' technology for building relationships. The identification shows that there is an increasing marginal cost of building additional relationships. This finding is consistent with Chen et al. (2004), who find that financial institutions have decreasing returns to scale in non-routine tasks. The model does a reasonable job of fitting the data. The total bank loans increased from \$5.16 to 8.62 trillion from 2002 to 2017 (vs from \$5.11 to \$8.54 trillion in the data). The un-targeted moments in the data is the cost of processing a dollar amount of loans, which decreased by 16% from 2012 to 2017 in the model (vs 16% in the data). The share of small business loans is 6.7% for all banks, and 5.4% for large banks (with loan more than 1 billion dollars) in 2002 (vs 6.7% and 5.1% in the data); small business loans are \$346 billion in the model (vs \$340 billion in the data) in 2002. The estimated model shows that small business loans decreased from \$346 to \$322 billion dollars because of IT improvement from 2002 to 2017. This identification strategy solves the challenges mentioned above because I do not identify the values of each

of the collection process. Technology has changed and continues to change the way we collect, process, and communicate information. This has fundamentally transformed the way financial markets and institutions operate. One of these changes is a greater reliance on hard relative to soft information in financial transactions. This has altered the design of financial institutions by moving decisions outside the traditional boundaries of organization.”

⁵I exclude data during the recessions because my model cannot explain fluctuations in the banking sector. However, my model does show that IT improvements makes banks to issue transaction lending to riskier borrowers and thus increases the risk in the pool of transaction lending.

parameter by targeting at the moments about the change of small business loans.

The model shows that the substitution effect contributes to at least 63% of the decline in the model, while the crowding-out effect contributes to at most 37%. In the quantitative model, the costs of processing each dollar of a transaction loan decreased by 46%, from \$0.0144 in 2002 to \$0.0078 in 2017. This decrease is large in comparison with the average loan spread of about 3%. However, for each dollar of a relationship loan, the bank needs to pay at least an additional \$0.0066 to build relationships, so the cost of relationship lending is reduced by at most 31%. Because the returns to banks are larger from transaction lending than from relationship lending, they substitute from relationship loans to transaction loans. In the model, the loan share of large banks with loans totaling more than \$1 billion increased from 76% to 86% (vs from 81% to 90% in the data) from 2002 to 2017; the share of small business loans decreased from 6.7% to 3.6% for all banks, but for large banks (with loan more than 1 billion dollars), it decreased from 5.4% to 2% (vs 5.1% to 3% in the data) from 2002 to 2017. Because large banks have smaller shares of small business loans, lending to small businesses declines.

There are debates about the desirability and effectiveness of policies to encourage lending to small businesses. A structural framework can be better for conducting counter-factual policy analysis, compared to a reduced-form approach. With my quantitative structural model, I compare three policies: subsidizing lending to risky small borrowers; subsidizing small banks with fewer than 100 million dollars of loans; and reducing banks' staying costs. A dollar of subsidy of \$100 to small business lending increases small business lending by \$79 as this policy reduces the substitution effect. However, a dollar of subsidy of \$100 to small bank's lending increases small business lending by \$0 because, even if this policy decreases the crowding-out effect as is suggested by Berger et al. (2005), it increases the substitution effect. Bordo and Duca (2018) suggest that we should reduce the regulatory burden on banks to reduce the exit of small banks and to increase lending to small businesses. I find that when small banks' (with fewer than \$100 million loans) staying costs are reduced by \$1 out of \$100, lending to small businesses increases by \$0.002. Therefore the policy of reducing banks' regulatory burden (for example, the repeal of the Dodd-Frank Act) may increase lending to small businesses, but not that much.

The paper contributes to literature by providing a general equilibrium framework to evaluate the consequences of technological advances and banking policies. The general equilibrium framework well addresses the competition among banks and banks' endogenous adoption of new technology, which are the challenges to relate IT improvement and banks'

productivity growth. The general equilibrium framework allows me to better evaluate the casual relationship between the consolidation and the decline of small business lending when natural experiments are not available for empirical work (Berger and Udell, 2002). The framework also considers the rational expectations of banks and the competition among large and small banks when evaluating policies. Thereby, I arrive at quantitatively different results from previous empirical work.

The rest of the paper is organized as follows. Section I is the contributions to literature. Section II presents key statistical features of the U.S. commercial banking market. Section III contains the model. Section IV presents the estimation of the model. Section V shows implications of the model. Section VI concludes. Proofs and tables are in the Appendix.

1 Contributions to Literature

First, this paper contributes to the recent literature on the decline in small business lending. Two pioneering studies (Cortés et al., 2018; Bordo and Duca, 2018) try to attribute this reduction to the increasing regulatory burden created by the Dodd-Frank Act, but they arrive at conflicting results. Bordo and Duca (2018) find that this policy makes it more difficult for small banks to survive, and that the increased regulatory burden has contributed to the decline in small business lending in the U.S. However, Cortés et al. (2018) do not find any positive correlations. Therefore it is not entirely clear why small business lending has declined. My paper offers an alternative explanation: improvements in information technology. I show that this factor may have contributed to a major part of the decline. Using this framework with IT improvements, I conduct policy experiments and find that when policy reduces the regulatory burden of small banks, lending to small businesses may increase little.

Second, this paper contributes to the literature on banking market consolidation and small business lending (Berger et al., 1998; Strahan and Weston, 1998; Peek and Rosengren, 1995; Berger, Bouwman and Kim, 2017). Berger et al. (2005) and Berger, Bouwman and Kim (2017) find that small banks still play a significant role in lending to small business and suggest that consolidation in the U.S. banking market may contribute to the decline in small business lending (also refer to Berger and Udell (2002) for a summary of related research). However, other studies find that the exit of small banks decreases or does not affect lending to small risky borrowers. My study finds that the consolidation is only correlated with the

decline in small business lending, but does not cause the decline. Both bank consolidation and the decline in small business lending are the result of IT improvements. Therefore, when we use a regression to establish a causal relationship between greater banking market concentration and the decline in small business loans, we may have the problem of omitted variables and establish a false causal relationship.

Third, this paper contributes to studies of technological improvements and productivity growth in the U.S. banking industry. Berger (2003) summarizes the difficulties of relating information technology improvements to observed productivity growth. First, firms may not adopt the best available technology. Second, productivity growth may not increase firms' profits, but instead benefit consumers through competition among firms. This study tackles this challenge by using a quantitative structural model that endogenizes the adoption of advanced technologies and competition among banks. I find that productivity in the banking sector grew by 46% from 2002 to 2017 due to IT improvements.

Fourth, this paper contributes to the literature on industry “shake-out.” The research on industry shake-out suggests that with the introduction of cost-saving technology, small firms exit and large firms gain market share (Hopenhayn, 1992; Hayashi, Li and Wang, 2017). Hayashi, Li and Wang (2017) show that the ATM market becomes more concentrated because large firms benefit more than small firms from the introduction of ATMs that accommodate debit cards. When the technology used in transaction lending improves, there is a shake-out in the banking market. Consistent with this study, transaction loans to safe borrowers in my model are similar to ATMs, and these safe borrowers receive more loans. By enriching the previous framework of shake-out with an alternative product—relationship lending, and with alternative borrowers—risky borrowers, I find that shake-out can be welfare-decreasing for these risky borrowers. This finding is different from the conclusions of previous research as I introduce different production technologies that improve at different rates.

2 Motivation Facts

The following figures and table show some key dynamic features of the U.S. commercial banking industry and the characteristics of U.S. firms. First, U.S. banks have increased their use of software. Second, U.S. banks have reduced lending to small businesses. Third, the U.S. banking market is increasingly concentrated. Fourth, younger firms are smaller and have higher rates of exit, but have the largest employment growth with 1 million dollars

of bank loans.

2.1 An Upward Trend in Technology Usage

Figure 1 shows the increasing use of software in the U.S. commercial banking sector. Banks' software stock, including prepared software (ENS1), custom software (ENS2), and own account software (ENS3) increased from about \$18 billion in 2002 to about \$36 billion in 2016, by 100% (in constant 2017 U.S. dollars). The data are from the Bureau of Economic Analysis (BEA), Current-Cost Net Capital Stock of Private Nonresidential Fixed Assets Table. Figure 2 shows that the cost of processing information per dollar of loans decreased over time, from .078% to .067% from 2012 to 2017.

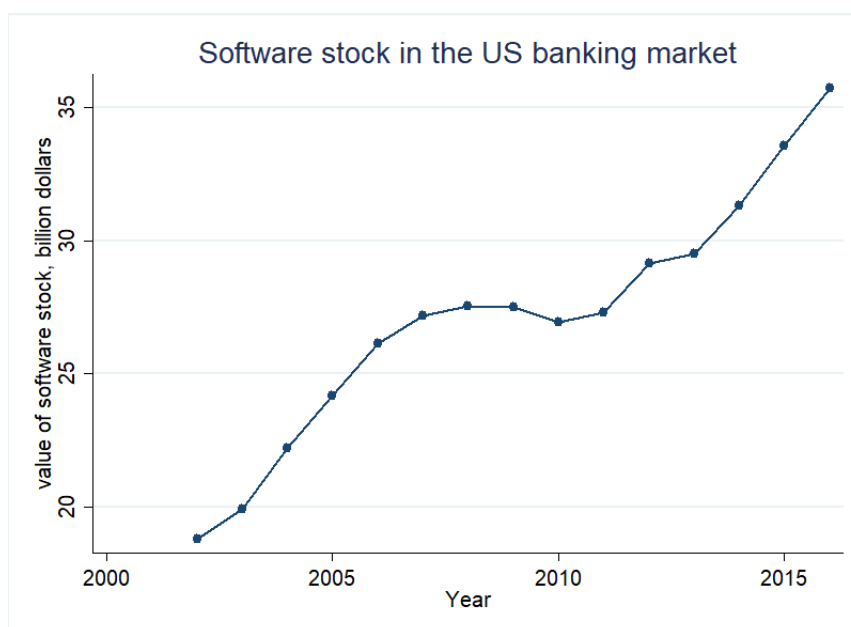

Fig. 1. The figure shows banks' software stock increased from \$18 to \$36 billion during 2002 to 2016 in constant 2017 dollars. Banks' software stock includes prepared software (ENS1), custom software (ENS2), and own account software (ENS3). The data are from the Bureau of Economic Analysis (BEA), Current-Cost Net Capital Stock of Private Nonresidential Fixed Assets Table.

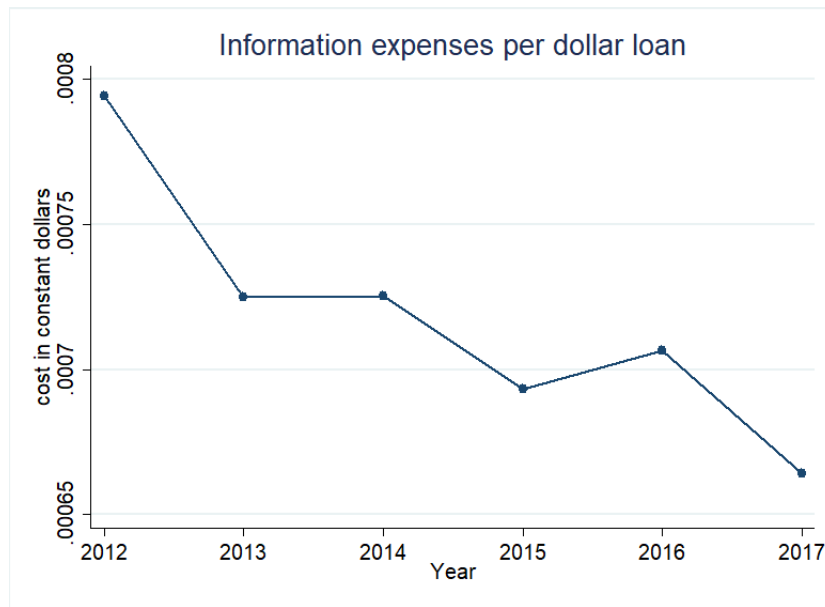

Fig. 2. The figure shows that the cost of processing information per dollar of loan decreased over time, from .078% to .067% from 2012 to 2017. This item represents total costs and fees incurred in processing bank's data, including computer services, technology expense and software expenses. The information costs of per dollar loans equal to banks' information expenses divided by total loans. Data are from Compustat Bank Fundamentals Annual.

2.2 The Trend of Lending Practice

I use data from the FDIC reports on U.S. depository institutions for 2002 to 2017. All the dollar amounts are in constant 2017 U.S. dollars. Figure 3 shows the decline in small business lending relative to total bank loans. Small business loans as a share of total bank loans decreased monotonically from about 6.7% to about 3.5%. Figure 4 shows the increasing concentration in the U.S. commercial banking market: the market share of large banks with loans of more than \$1 billion increased from 82% to 90%; the number of small banks with loans of less than \$100 million dollars decreased from 4,707 to 2,072.

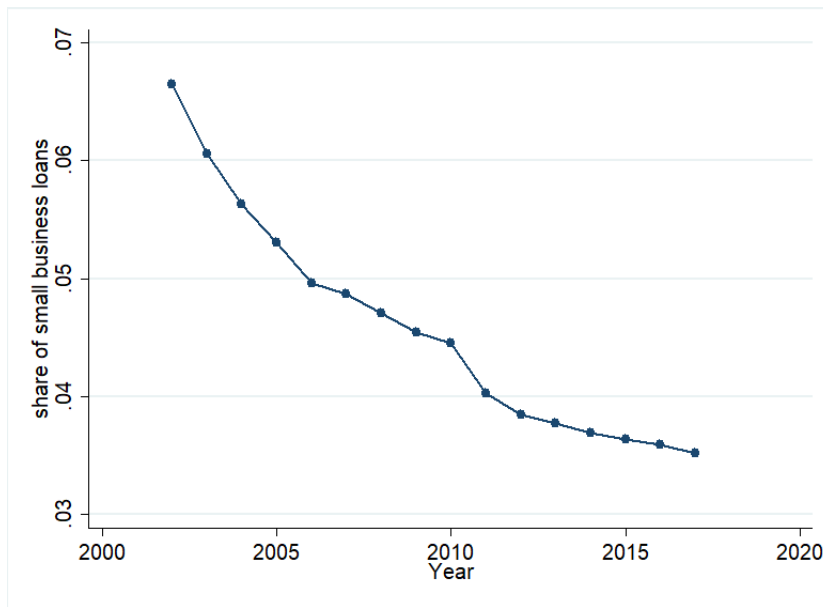

Fig. 3. The figure shows that small business loans as a share of total bank loans decreased monotonically from about 6.7% to about 3.5% from 2002 to 2017. The data is from the FDIC reports on U.S. depository institutions.

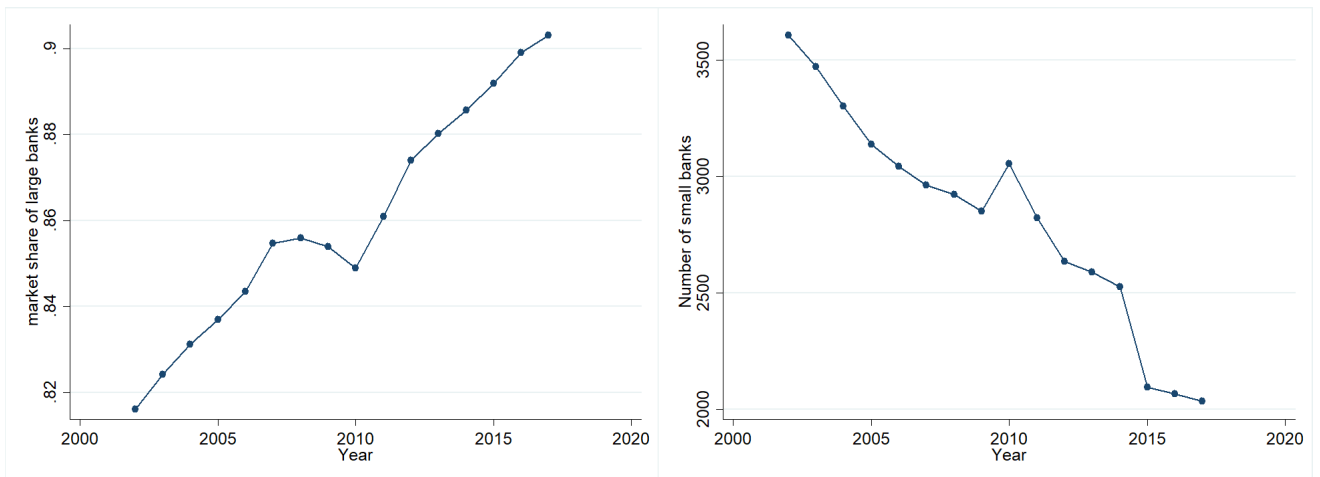

Fig. 4. The figure on the left shows that the market share of large banks with loans of more than \$1 billion increased from 82% to 90%. The figure on the right shows that the number of small banks with loans of less than \$100 million decreased from 4,707 to 2,072. The data is from the FDIC reports on U.S. depository institutions. Dollars are in 2017 constant US dollars.

2.3 Firm Sizes, Ages, Exit Rates, Loan Denial Rates and Job Creation Rates

I use data from the Business Dynamics Statistics (BDS) from 1977 to 2015, the 2014 Annual Survey of Entrepreneurs, U.S. Census Bureau and Brown, Earle and Morgulis (2015). Table.1 shows that younger firms have lower loan approval rates conditional on

application, but can create more jobs with \$1 million dollars of financing. Figure 5 shows that younger firms are smaller and have higher exit rates.

Table.1 inserted here.

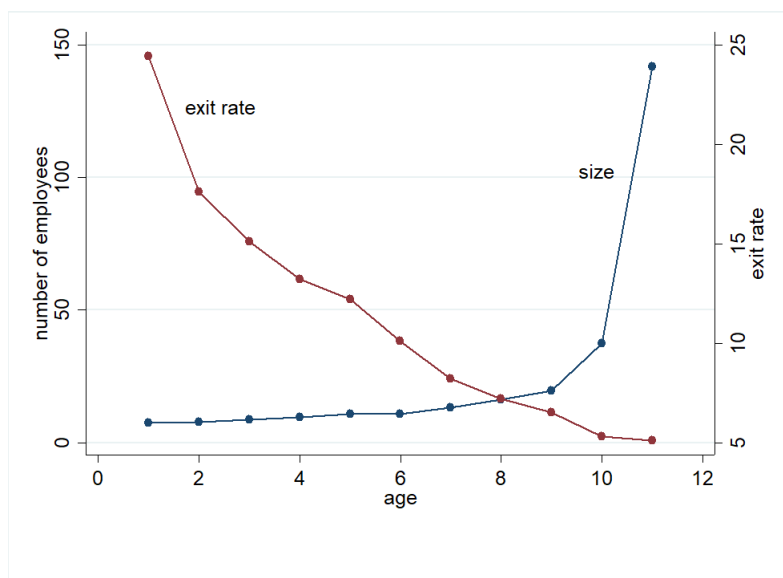

Fig. 5. This figure shows that small and young firms have higher exit rates than large and old firms. Firms in the first age group are younger than two years old. Firms in the second age group are two years old. Firms in the third age group are three years old. Firms in the fourth age group are four years old. Firms in the fifth age group are five years old. Firms in the sixth age group are six to ten years old. Firms in the seventh age group are eleven to fifteen years old. Firms in the eighth age group are sixteen to twenty years old. Firms in the ninth age group are twenty-one to twenty-five years old. Firms in the tenth age group are over twenty-five years old. The data are from the Business Dynamics Statistics (BDS) from 1977 to 2015.

3 Model

In this section, I construct an infinite-horizon model with discrete time periods. The economy is populated with borrowers and commercial banks (“banks” henceforth). Borrowers have no preference or behaviors in the model. A borrower lives for one period. A borrower has a project that needs \$1 dollar of financing from a bank. His delinquency

rate is unknown to banks. Banks take deposits and issue loans to maximize expected discounted profits. Banks have productive assets for assessing borrowers' delinquency rates. The evaluation of a borrower's delinquency rate is a statistical analysis, which is based on borrowers' hard information. Banks can also choose to invest in long-term relationships with borrowers to learn about changes in the borrower's financial condition, and to adapt lending terms to the evolving circumstances of the firm (Rajan, 1992; Von Thadden, 1995; Bolton et al., 2016). In their models, the bank-borrower relationship gives the bank an option to restructure the debt when the borrower is delinquent and thereby increase the bank's returns.

I model relationship banking by simplifying Bolton et al. (2016): banks have higher returns from a delinquent borrower in relationship lending than in transaction lending. Hence, risky borrowers receive relationship lending and safe borrowers receive transaction lending. I add two features to Bolton et al. (2016): first, a bank's marginal cost of building an additional relationship is increasing in the amount of relationships built; second, a bank can accumulate assets in order to grow and can choose to exit. Over time, the technology of assessing hard information improves relative to the technology of building relationships. As banks have increasing marginal costs of building additional relationships, banks find it more profitable to switch to transaction lending from relationship lending when IT improves. As banks gain economy of scale in accumulating assets, IT improvements allow larger banks to grow faster and gain market share. Because IT improvements also intensify the competition in the deposit market and increase the cost of deposits, smaller banks cannot afford to stay and may choose to exit.

I do not model borrowers' behaviors or choices. Some may argue that improvements in IT allow borrower to search more efficiently for the best loan offers, and that therefore advanced information technology will promote matching between banks and borrowers. I model the efficiency improvements of matching between borrowers and banks from the perspective of banks. In the model, advanced information technology allows banks to evaluate more borrowers, which leads to more efficient matching between banks and borrowers.

3.1 Model Details

Time Line: There are infinite periods $t = 0, 1, 2, \dots$. In each period t , there are four dates, $d = 0, 1, 2, 3$. On date zero, a bank assesses borrowers. On date 1, based on a borrower's delinquency rate, the bank decides whether to lend to the borrower. If the bank chooses to lend to the borrower, the bank decides by relationship or transaction lending. On date 2,

the bank receives the return from its loan. On date 3, after seeing its cost to stay for the next period, the bank decides whether to stay in the market and decides the amount of its assets for the next period.

Preference and endowments: Banks are risk neutral and are endowed with assets for evaluating borrowers. Borrowers have projects, but no money to invest in them.

Types of securities are risky bank loans and riskless deposits. A bank issues a loan of \$1 to finance a borrower's project. The borrower and his project exist for one period. Borrowers differ in the delinquency rates of θ , $\theta \in [0, 1]$. If the borrower repays on time, the payoff to the bank is R_H , the sum of principal and interest. If the borrower is delinquent on his debt, the bank receives different returns from transaction and relationship lending. In transaction lending, the bank liquidates the borrower's project and receives the liquidation value, R_L . In relationship lending, the bank can restructure the debt and receives a higher return, R_R , $R_R > R_L$. I abstract from the process of debt restructuring in Bolton et al. (2016), as this part is not relevant to my results. In the model, loan rates are exogenously given. If banks price loans according to borrowers' risk, the results of the model will not change. As information technology improves, banks will increase their loan rates to risky borrowers and these risky borrowers will not be able to profit from borrowing from banks. Similarly, risky borrowers who receive relationship loans will still be hurt by technology improvements. Deposits are from a competitive deposit market with an increasing supply function, $r = R_H - e^{-n_r \log(D)}$, where r is the deposit interest rate, D is the supply of deposits, and n_r measures the elasticity between the deposit supply and the deposit interest rate. When the deposit rate increases, the supply of deposits increases.

Return from a relationship loan:

$$q^R(\theta) = (1 - \theta)R_H + \theta R_R - r$$

Return from a transaction loan:

$$q^T(\theta) = (1 - \theta)R_H + \theta R_L - r$$

On date 0, measure of B newborn banks enter the market. A newborn bank has assets z^0 , which is drawn from a log-gamma distribution, $\log - \text{gamma}(\mu_z, \sigma_z)$. All borrowers apply to all banks (the incumbents and the new entrants). At this time, banks have no information about borrowers' delinquency rates.

On date 1, banks use their assets to determine the delinquency rates of borrowers at no cost. The number of borrowers evaluated by a bank is determined by banks' technology and the bank's assets in this period. The rationale behind this number is an optimal decision by the bank. The bank decided on the amount of its assets for this period in the previous period and cannot make any changes thereafter. Given a bank's assets and the current technology, the bank decides how many borrowers to evaluate. The bank will make the maximum profit if it uses all of its assets to evaluate borrowers. A bank with assets z_t determines the delinquency rates of m_t borrowers,

$$m_t = M_t z_t^\alpha$$

, where $\alpha \in (0, 1)$ measures the return to the scale in banks' technology of assessing borrowers' hard information and $M_t = e^\lambda M_{t-1}$. The parameter M_0 measures banks' technology at period 0 and λ measures the advancement of bank's technology of each period.

A bank chooses whom to lend to and whether to use a relationship or transaction loan based on the delinquency rates of borrowers. If a bank makes a relationship loan to a borrower, it pays a cost c to build a relationship with the borrower. The cost of building a relationship is an increasing function of how many relationships the bank builds, where $c(L^S) = \frac{1}{F(\omega+1)}(L^S)^\omega$, L^S is the number of relationships that the bank builds, ω captures the elasticity between marginal costs of building relationships and the number of relationships, and F measures the average costs of building relationships. In the data, large banks have smaller shares of small business loans (relative to total loans), therefore, $\omega > 0$. Hence in the model, banks have greater decreasing return to scale of lending to small business borrowers, compared to lending to large corporations. This is equivalent to say that banks have some fixed costs of making loans.

The process of building relationships is as follows: the bank manager sends loan officers to collect soft information about a borrower, such as his managerial ability, the condition of his business, and his reputation among neighbors. With this information collected, the loan officer can better monitor the cash flow from the borrower's project. During the process, a loan officer may neglect his responsibilities. Thus the manager needs to monitor and incentivize the loan officers. Because a manager has limited time, if he monitors many loan officers he cannot monitor them as efficiently as managers who monitor only a few loan officers. In this case the manager needs to give his loan officers even more incentives. When a bank has many borrowers to build relationships with, it hires many loan officers. Hence a bank has an increasing marginal cost of building relationships. Chen et al. (2004) show that

financial institutions have decreasing returns to scale in managing portfolios, especially in non-routine tasks that require employees' subjective judgments. Building relationships to acquire borrowers' soft information is a task of this type.

On date 2, a bank earns its profits from all the loans he finances. If a borrower repays on time, the bank receives R_H , the sum of principal plus interest. If the borrower is delinquent on the debt, the bank decides whether to liquidate his project or restructure his debt. In transaction lending, the bank liquidates the project and receives the liquidation value, R_L . In relationship lending, the bank has the option to restructure the debt and receives R_R , a higher amount than the liquidation value. Think about two types of loans: a mortgage loan and a loan to a high-tech start-up. For both, if the borrower repays on time, the lender receives the principal and interest. In the case of a mortgage, after issuing the loan, the lender seldom has contact with the borrower; if the borrower does not repay on time, the lender will repossess the house and sell it, usually at a discounted price. In the case of a loan to a high-tech start-up, after issuing the loan, the lender will contact the firm's CEO frequently so as to monitor the firm's cash flow, innovation activities, and management decisions. If the firm does not repay the bank on time, the lender usually knows the reason for the delinquency. If the bank and the firm's CEO agree on the firm's business plan, the bank will continue its financing; otherwise, the bank will negotiate with the lender to get some of its money back. This process is debt restructuring, which increases banks' returns.

On date 3, after the cost of staying, e_t , is known, the bank decides whether to stay and decides its assets for the next period, z_{t+1} if stays,

$$z_{t+1} = (1 - \delta_z)z_t + Az_t^{1-\gamma}g_t^\gamma$$

where e_t is from a log-gamma distribution $\log - gamma(\mu, \sigma)$, g_t is the money used for assets accumulation, δ_z is the depreciation rate of assets, A and γ are constant parameters, and $0 < \gamma < 1$. The parameter A , the bank's assets, z_t and the technology for assessing borrowers determine the bank's return from the investment of g_t . The money used for investment is borrowed from future profits. The model assumes that banks can borrow from another debt market besides deposit market to finance its investment in IT. Banks with more assets, has larger returns from this investment. When making the investment on productive assets, banks need to trade off the cost of this borrowing and the benefit to its continuation value, which depends on the current level of its assets. As a result, when the technology for evaluating borrowers is improving, the return gaps between large

and small banks increase. Large banks benefit more from technological improvements than small banks. The process by which banks accumulate assets can also be seen as a process of banks utilizing new technology. Large banks are assumed to be better at utilizing new technology than small banks. People find that large banks have usually been first to adopt advanced technologies and benefit more from the adoption (Berger, 2003). For example, the transaction website adoption rate varied greatly by bank size. By the end of 2001, 100% of the largest banks (banks with over \$10 billion in assets) had transaction websites, while 29.1% of the smallest banks (with assets below \$100 million) had transaction websites.

Bank's Decisions

The bank with assets z_t solves the following problem: first, based on a borrower's delinquency rate, θ , the bank decides whether to lend to him. If the bank chooses to lend to him, it decides whether to issue a relationship or a transaction loan. Second, after it sees the cost of staying in the market, the bank decides whether to stay in the market. Last, if the bank decides to stay, it determines its assets for the next period.

$$V_t(z_t) = \max_{\{z_{t+1}, I^R(\theta, z_t), I^T(\theta, z_t)\}} \{M_t z_t^\alpha \int_{\theta} [(q^R(\theta) - c)I^R(\theta, z_t) + q^T(\theta)I^T(\theta, z_t)] dU(\theta) + E_e[\max\{\beta V_{t+1}(z_{t+1}) - g_t - e_t, 0\}]\}$$

s.t.

$$z_{t+1} = (1 - \delta_z)z_t + A z_t^{1-\gamma} g_t^\gamma$$

where $I^R(\theta, z_t)$ is the indicator of relationship lending, $I^T(\theta, z_t)$ is the indicator of transaction lending, g_t is the amounts of money used for the producing new assets, e_t is the cost of staying for the next period, δ_z is the depreciation rate of assets, β is the discounting factor and $V_t(z_t)$ is the continuation value of the bank with assets z_t in period t . Banks can borrow freely and at a zero interest rate from their future profits to accumulate assets and to cover the cost of staying.

Competitive Equilibrium

A competitive equilibrium is a deposit interest rate r_t^* , a distribution of bank's assets Ω_t , a set of bank's decisions $\{z_{t+1}, I^R(\theta, z_t), I^T(\theta, z_t)\}$, and the induced valuation process $V_t(z_t)$, such that:

A bank's decision $\{z_{t+1}, I^R(\theta, z_t), I^T(\theta, z_t)\}$ solves the problem of the bank with assets z_t at the given deposit interest rate r_t^* ,

The deposit market is cleared at the market rate r_t^* ,

$$\int_{z_t} \int_{\theta} M_t z_t^\alpha (I^R(\theta, z_t) + I^T(\theta, z_t)) dU(\theta) d\Omega_t = S^{-1}(r_t^*)$$

Proposition: For the bank with assets z , there exists two thresholds $\theta^* < \theta^{**}$, such that if the borrower has a delinquency rate of θ that $\theta < \theta^*$, the bank finances him with transaction lending; if the borrower has a delinquency rate of θ that $\theta^* \leq \theta \leq \theta^{**}$, the bank finances him with relationship lending; and if the borrower has a delinquency rate of θ that $\theta > \theta^{**}$, the bank will not finance him. Also, if a bank has increasing marginal costs of building relationships,

$$\frac{\partial \theta^*}{\partial z} > 0, \quad \frac{\partial \theta^{**}}{\partial z} < 0$$

Intuitions: The additional expected return from a relationship, $\theta(R_R - R_L) - c$, Therefore, if a borrower's project is too safe, the additional return from a relationship exceeds the cost of building the relationship. So, there is a θ^* such that the cost and the return are equal. On the other hand, when a project is too risky, its expected return is less than the cost of financing it, so there is a θ^{**} such that the bank will not finance projects with a delinquency rate of $\theta > \theta^{**}$. In first case where banks have increasing marginal costs of building relationships, when a bank has more assets, it can evaluate more borrowers; if the bank chooses to build more relationships, the bank's cost of building relationships increases. This increase reduces the surplus from relationships, and the bank may extend transaction loans to riskier borrowers who received relationship loans before; in this case, θ^* shift to the left. In addition, the bank's return from the riskiest borrowers, who received relationship loans before, becomes negative. Therefore the bank will no longer lend to these borrowers; in this case θ^{**} shift to the right. The explanation is similar when banks have better lending technology. In the second case where banks have decreasing marginal costs of building relationships, the conclusions are on the contrary.

The proposition qualitatively implies that as information technology improves and banks become more efficient in evaluating borrowers, high-risk borrowers will receive fewer loans; those that do receive loans are more likely to receive transaction loans. The model also implies that transaction loans are associated with a riskier pool of borrowers with IT improvements.

Figure 1: Shifts of Two Thresholds

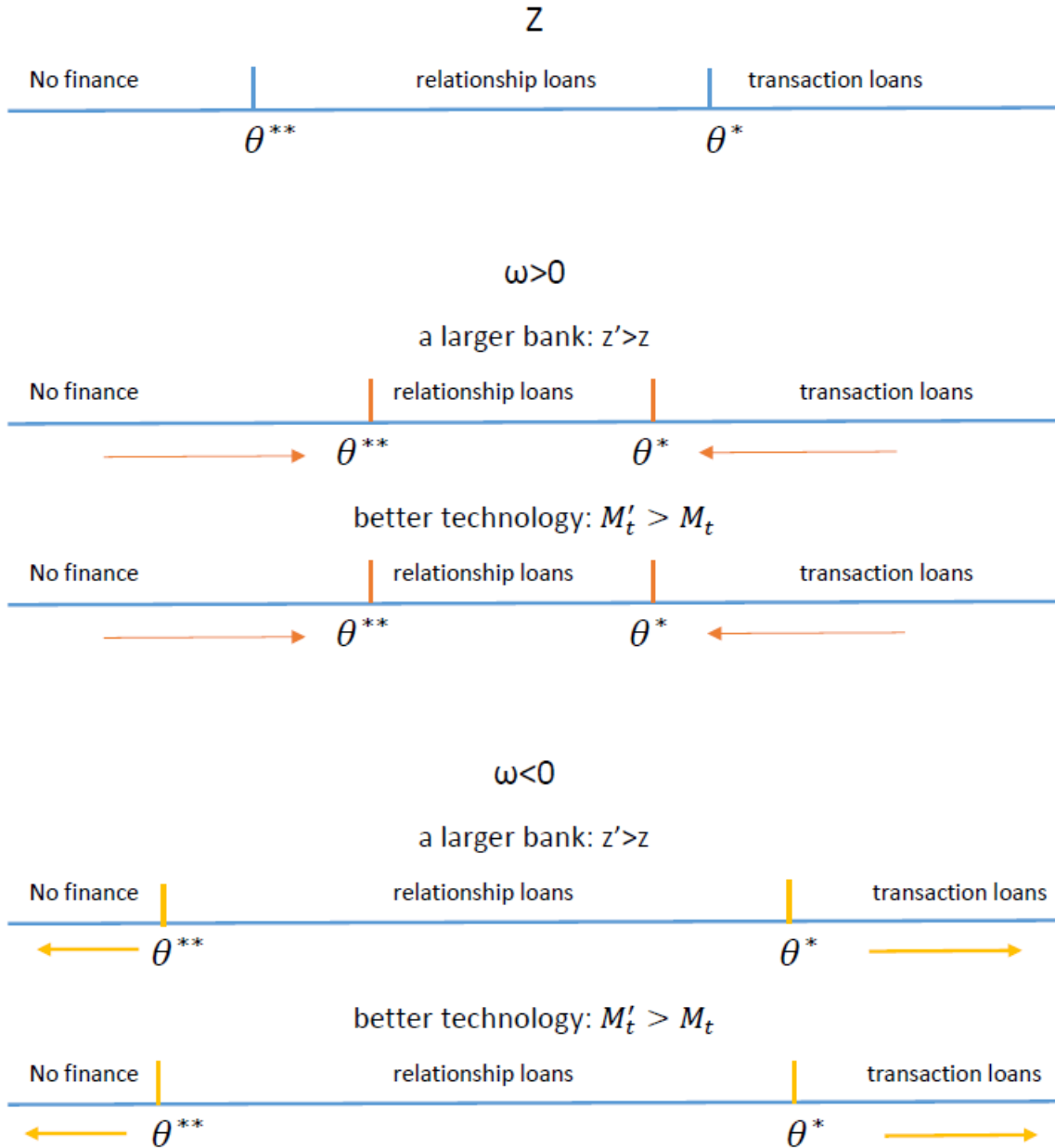

Fig. 6. This figure shows that there are two thresholds that determine a bank's transaction lending and relationship lending. From left to right, borrowers become safer with lower delinquency rates. For the bank with assets z , there exists two thresholds $\theta^* < \theta^{**}$, such that if the borrower has a delinquency rate of θ that $\theta < \theta^*$, the bank finances him with transaction lending; if the borrower has a delinquency rate of θ that $\theta^* \leq \theta \leq \theta^{**}$, the bank finances him with relationship lending; and if the borrower has a delinquency rate of θ that $\theta > \theta^{**}$, the bank will not finance him. When a bank's has increasing marginal costs of building relationships ($\omega > 0$) and its assets increase, its risk tolerance for transaction loans increases and its risk tolerance for relationship loans decreases (that is, θ^* increases and θ^{**} decreases); when a bank's has decreasing marginal costs of building relationships ($\omega < 0$) and its assets increase, its risk tolerance for transaction loans decreases and its risk tolerance for relationship loans increases (that is, θ^* decreases and θ^{**} increases).

4 Estimation

I estimate the model to the U.S. individual commercial bank data to quantify the IT improvement and its effects on lending to small businesses. I identify a set of parameters with which the simulated model are quantitatively consistent with the observed behaviors of the U.S. commercial banks. In the data, the bank size distribution changes over time: banks make more loans and the market concentration increases. Cross-sectionally, larger banks have a smaller share of small business lending. The model does a very good job of explaining the change of bank size distribution from 2002 to 2017 and the dollar amount of small business loans and the share of small business loans for all banks and for large banks (with loans more than \$1 billion) in 2002. The estimation strategy solves the identification challenges mentioned in the introduction⁶. I do not estimate the model by targeting at the moments about the change of small business lending from 2002 to 2017; Instead, I simulate the estimated model to evaluate to what extent, technological improvement can change the supply of small business lending. By doing so, I separate the effect from supply side.

4.1 Data

The data are from the Federal Deposit Insurance Corporation (FDIC), Statistics on Depository Institutions (SDI). The data are all reported in June of each year. I use data from 2002 to 2017 and exclude data from 2008 to 2011, the years of the so-called Subprime Crisis. First, since I do not introduce economic fluctuations in the model, I cannot explain the data during a crisis using this model. Second, the market for small business lending is far from securitized in comparison with mortgage lending. The collapse of the loan securitization market may not have affected lending to small businesses. Third, the decline in lending to small businesses may not come from the demand side. Although during a crisis many small firms exit, the demand for loans by small businesses is never satisfied. According to statistics from a financial service company, Behalf, in 2012, 43% of small businesses said that they were unable to find sources for the business financing they needed

⁶ First, in the data, we cannot see the demand for small business loans. Without a good instrument variable for the supply of small business lending, it is hard to establish casual effect between IT improvements and decline of lending to small businesses. Second, a bank's costs of IT is a choice variable for the bank as well lending to small businesses.

(NSBA 2012), and only 13% of applicants were approved for a small business loan in 2013 (Venture Capital 2015). I exclude banks that made no small business loans. These banks usually are small and specialized in a type of lending, such as mortgages or agricultural loans.

A bank's total loans in the model are measured by total loans and leases net of unearned income⁷. I assume that the loan size distribution does not change much. Some argue that the development of the securitization market allowed non-jumbo mortgage loans to become more liquid and that, as a result, banks issue more non-jumbo mortgage loans and fewer jumbo mortgages. The average loan size would thus become smaller. However, this change would have little effect on the loan size distribution, as jumbo mortgages account for less than 2% of all mortgages. Relationship loans are measured as loans to small businesses. Small business loans are loans with an original amount of \$1 million or less that are reported as C&I loans to U.S. addresses. Banks build relationships when they lend to small firms because small firms are usually informationally opaque (Berger and Udell, 1995, 2002). Transaction loans are defined as a bank's total loans minus its relationship loans. They are car loans, consumption loans, mortgages, and large C&I loans. Because of the development of the securitization market, these loans can be easily securitized and sold. Loans in delinquency are loans that are past due by more than 30 days, interest is unaccrued, and the loans are charged off. Table.2 shows the definition of each variable. Table.3 shows the summary of statistics

The cost of data processing is from Compustat, Bank Fundamental Annual. This data set had 3,200 banks (in each year) from 2012 to 2017. The average total loans of these banks is \$28,025 million. However, in the FDIC data set, the average loan amount for a bank is \$7,880 million. These banks are larger than the average U.S. bank. In the model, banks do not differ from productivity of processing information in a given year even though larger banks have slightly larger marginal costs of evaluating hard information. Therefore, the information costs per dollar loans are very similar across all banks in a given period. The data processing costs represent total costs and fees incurred in processing banks' data, including the costs of computer services, technology, and software. The data show that, from 2012 to 2017, the data processing costs per dollar of loans decreased by 16%. The

⁷Unearned revenue is money received by an individual or company for a service or product that has yet to be fulfilled. Unearned revenue can be thought of as a "prepayment" for goods or services that a person or company is expected to produce for the purchaser. As a result of this prepayment, the seller has a liability equal to the revenue earned until delivery of the good or service. Source: <http://www.investopedia.com/terms/u/unearnedrevenue.asp>

costs for a dollar of loans equal to the information expenses divided by bank total loans in dollar amount. This is not a perfect measure of bank's costs of processing information for a dollar of loans. Perfectly, we should use the information costs divided by the dollar amount of newly originated loans. However, I cannot see how many loans are originated in a given year. In the data, bank total loans increase at a quite constant rate and thus, the flow of loans is probably a constant proportion of the stock of loans. In the estimation, I only need to care about by what percentage, the information costs for a dollar of loans has decreased. Therefore, the measure I use is a good proxy for banks' costs of information for a dollar of loans.

Table.2 inserted here.

Table.3 inserted here.

4.2 Estimation Method and Results

I estimate the model using the simulated method of moments. I select the values of parameters to match the key moments in the data with the simulated ones from the model. For each group of parameters, I compute the optimal choices of each bank and the deposit interest rate in the equilibrium in each period. The initial period in the model is the year of 2002. The solution to the banks' problems is provided in Appendix 2. I then compute the moments from the model and compare them with the moments from the data. The search will stop until distance between the moments in the model and the moments in the data is small enough. The weight put on each moment is normalized to 1. The moments include the dollar amounts of total loans, the standard variations of total loans, the loan shares of banks with loans totaling more than \$1 billion, the average of banks' total loans for banks in the top 25% percent, the average of banks' total loans for banks in the bottom 25% percent, the dollar amount and the share of small business loans in 2002, the share of small business loans by the top 25% of banks in 2002, the loan delinquency rates in 2002 and 2017, and the average amount and standard variations of total loans of entry banks from 2002 to 2007 and from 2012 to 2017. I put three restrictions in the estimation. First, the average bank's productive assets increase over time because the value of bank software increases over time. Second, the ratio of the standard deviations of bank loans to the sum of loans increases over time. Third, the ratio of the average dollar amount of loans by banks

in the top 25% to the average dollar amount of loans by banks in the bottom 25% increases over time. These specifications are consistent with the data observations.

The estimation is to identify the parameters in a bank's technology for evaluating borrowers' delinquency rates, M_0, λ, α , the parameters in a bank's technology for building relationships, F, ω , the parameters in the deposit supply function, n_r , the parameters in the technology used by banks to accumulate assets, δ_z, A, γ , the distribution of the staying costs, μ, σ , the parameters that characterize the returns from the projects, R_H, R_L, R_R , and the parameters that characterize the asset distribution of newly entered banks, μ_z, σ_z . I estimate period 0 in the model to the year of 2002. I additionally assume that in the first period, incumbent banks have assets z that are from the distribution of *log-gamma*(μ_0, σ_0). The parameter R_H is calculated as the ratio of incomes from loans to total loans, 1.0375. Assets depreciating rate δ_z is set to 0.004. The discounting factor β is set to 0.996. The number of newly entered banks (B) are calculated as total de nova banks from 2003 to 2007 and from 2012 to 2017 to the number of years, 89.

I explain the identification of each parameter in this paragraph. The first period of the model is estimated to the year of 2002. The initial distribution of banks' productive assets is identified from the mean and the standard deviation of bank total loans in 2002. The parameter α is identified from the growth rate of the standard deviation of total loans during 2002 to 2017: a larger α increases the growth rate. The parameter α measures the economy of scale in a bank. Overtime, the distribution of banks' productive assets becomes more dispersed. When banks have greater economy of scale to do lending, the standard deviations increases more from 2002 to 2017. The parameter M_0 is identified from the difference of total loans between large banks (with loans more than \$1 billion) and small banks (with loans fewer than \$1 million): a larger M_0 increases the difference. The parameter M_0 measures the initial level of lending technology. As better lending technology favors larger banks, thus a larger M_0 , a larger difference. The parameter F is identified from the total amount of small business loans: a larger F increases the amount of small business loans. The parameter F measures the average costs of building relationships, a larger F , a smaller costs and thus, more relationship loans. The parameter ω is identified from the share of small business loans for all banks and for large banks: a larger ω increases the difference between these two shares. The parameter ω measures the elasticity between the marginal costs of building relationships and the number of relationships. With a larger ω , large banks have greater decreasing return to scale in building relationship loans, and then, compared to small banks, they have smaller shares of small business loans. The parameter

λ is identified from the increase of total loans from 2002 to 2017: a larger λ increases the loan growth rates; this parameter measures the advancement rate of technology. The parameter γ is identified from the change of loan share of large banks: a larger γ increases the growth rate of the market concentration; this parameter measures banks' economy of scale in accumulating productive assets. The parameter A is identified from the difference in the change of total loans for banks at the top and bottom 25%: a smaller A increases the difference. The parameter n_r is identified by the delinquency rates: a larger n_r decreases the delinquency rates; a larger supply elasticity of deposits, a larger deposit rate with the same amount of deposits, and therefore, a lower delinquency rate. The parameter μ_z, σ_z are identified from the mean and standard deviation of total loans of newly entered banks. Other parameters are identified jointly. The standard errors are calculated using the method in Bazdresch, Kahn and Whited (2018). Table.4 shows the value for each parameter and the corresponding moments used to identify them.

The model does a reasonable job of fitting the data. In the model, for the years 2002–2017, total loans increase from \$5.16 to \$8.6 trillion (vs \$5.11 to \$8.54 trillion in the data). For the same period, the standard variations of bank loans increase from \$8.69 to 16.2 billion (vs \$8.78 to \$24.6 billion in the data). The loan delinquency rates decrease from 2.33% to 2.3% (vs 2.37% to 2.14% in the data) from 2002 to 2017. The average bank loans of banks in the top 25% increase from \$2.36 to \$4.92 billion (vs \$2.43 to \$6.58 billion in the data) from 2002 to 2017. The average bank loans of banks in the bottom 25% increase from \$14.7 to \$38.6 million (vs \$20.7 to 31.5 million in the data) from 2002 to 2017. The loan share of large banks with loans totaling more than \$1 billion increases from 76% to 85% (vs 81% to 90% in the data) from 2002 to 2017. The share of relationship lending (small business lending) decreases from 6.7% to 3.7% (vs from 6.6% to 3.5% in the data); for large banks (with loan more than 1 billion dollars), it decreased from 5.4% to 2% (vs 5.1% to 3% in the data) from 2002 to 2017. The dollar amount of relationship lending decreases from \$345 billion to \$322 billion (vs from \$340 billion to \$301 billion in the data) from 2002 to 2017. The probability of being a small bank with asset below \$100 million decreased by 17% (vs 18% in the data) from 2002 to 2017. The mean of loans of newly entered banks is \$671 million in the model (vs \$675 million in the data); the standard variation of loans of newly entered banks is \$5.7 billion in the model (vs \$5.1 billion in the data).

The most important untargeted moment is the cost of data processing per dollar of loans issued. In the model, it shrinks by 15.8% (the cost of processing hard information in the model is equal to the aggregate bank productive assets divided by bank total loans) from

2012 to 2017. In the data, it shrinks by 16%.

Table.4 inserted here.

4.3 Comparative Analysis

The comparative analysis provides intuition for my identification of each parameter. I group the parameters in three categories. Group one includes parameters whose increase will increase total loans but reduce relationship loans, including, $M_0, \alpha, \mu_0, \sigma_0$. Group two includes parameters whose increase will increase total loans and relationship loans, including, $F, -\omega, R_R, -n_r$. Group three includes parameters whose increase will increase the growth rate of total loans, including, $\lambda, A, -\gamma$. The common features among parameters in the same group create a problem for identifying them.

To identify the parameters in the first group, I need to use the ratio of loan standard variation to total loans, defined as r_{1t} and the ratio of average loans of large banks (banks in the top 25%) to average loans of small banks (banks in the bottom 25%), defined as r_{2t} , where $t = 1, \dots, 12$. I increase M_0 from 1339 to 1636, increase α from .89 to .9, decreases from 1.09 to .88, increase μ_0 from 21 to 21.2, and increase σ_0 from .4 to .42 (Table.5). Only an increase of μ_0 can increase $\frac{r_{2,12}}{r_{2,1}}$ and only an increase of σ_0 can increase $\frac{r_{1,12}}{r_{1,1}}$.

To identify the parameters in the second group, I need to use the moments of loan delinquency rates, the number of small banks with loans totaling less than \$100 million, and the loan share of banks with loans totaling more than \$1 billion. I increase F from 148 to 181, decrease ω from .0279 to .0259, increase R_R from .55 to .56, and decrease n_r from .152 to .15 (Table.6). Only an increase of $-n_r$ can increase the loan delinquency rate in 2017; only an increase of F can decrease the loan share of large banks with loans more than 1 billion dollars in 2017; an increase of R_R decreases the number of banks with loans fewer than 100 million dollars in 2017.

To identify the parameters in the third group, I need to use r_{1t} and r_{2t} again. I increase λ from .0365 to .043, decrease γ from .31 to .29, and increase A from .36 to .38 (Table.7). Only a decrease of γ can increase $\frac{r_{1,12}}{r_{1,1}}$ and only an increase of A can increase $\frac{r_{2,12}}{r_{2,1}}$.

Table.5-7 inserted here.

5 Counterfactual and Policy Experiments

In this section, I conduct one decomposing analysis and three policy experiments. I decompose the effects of the substitution mechanisms and the crowding-out mechanisms. I find that the first mechanism contributes to 63% of the decline in small business loans in the model. Consistent with the results from the decomposing analysis, the policy experiment shows that to encourage lending to small businesses, policy should subsidize lending to small businesses rather than subsidize small banks.

5.1 Decomposing the Effects from Two Mechanisms

In this experiment, I decompose the relative importance from substitution effect and crowding out effect. The model shows that the cost of processing hard information in a loan application for \$1 million decreased from \$720 in 2002 to \$389 in 2017. As in the model, a bank on average approves 5% of loan applications it evaluates. Therefore, per dollar transaction loan, a bank saves \$0.66 cents (that is, $\frac{720-389}{1000000} \div 5\%$). This number is large if we compare it to the average loan spread, about \$3 cents. It also means that the cost of bank transaction lending is reduced by 46%. However, for each dollar of a relationship loan, the bank needs to pay at least an additional \$0.0066 (that is, $\frac{1}{F(1+\omega)}$) to build the relationship, so the cost of relationship lending is reduced by at most 31%. Since technological improvements benefit transaction lending more than they do relationship lending, banks replace relationship loans with transaction loans. In the model, because large banks are less constrained in their ability to issue more loans, large banks benefit more from technological improvements than small banks and crowd out small banks. The quantitative model infers that a bank with an additional \$1,000 of productive assets can produce at most \$1,726 in higher returns (that is, $(0.05\alpha(M_{12} - M_1) + 0.05\alpha(M_{12} - M_1)A\gamma(1 - \gamma))(R_H - r)$) as a result of improved IT.

To decompose, I keep the substitution effect and shut down the crowding-out effects between large and small banks. I keep the distribution of bank productive assets the same in each year. Under this condition, small business loans decrease by \$15 billion dollars, rather than the \$24 billion in the benchmark model. I thus conclude that the substitution effect accounts for at least 63% of the decline.

5.2 Policy Experiments

Using the quantitative model, I experiment with three policies to encourage lending to small borrowers and compare their effects on small business loans in 2017. Table. 8 compares the effects from different policies.

In the first policy experiment, I subsidize banks with 1% of their loan amounts, when lending to borrowers with delinquency rates greater than or equal to 5%. This policy reduces the substitution effects. According to the U.S. Small Business Administration, from 2002 to 2009 more than 90% of small business loans (in dollar amount) had a delinquency rate greater than 5%, and in the model all relationship loans have a delinquency rate greater than 4.9%. The benchmark model shows that loans to all borrowers with delinquency rates greater than or equal to 5% decreases from \$159 billion to \$90 billion; while other borrowers receive more loans from 2002 to 2017. Thus the model indicates that many risky small businesses receive fewer loans than before, and this reduction in lending to risky small businesses leads to a decline in small business lending. Therefore I only subsidize lending to risky borrowers. In comparison with the benchmark model, a borrower with a delinquency rate greater than or equal to 5% receives 4 times more loans in 2017 (from \$90 to \$428 billion), and other borrowers also receive more loans under this policy. This subsidy costs \$4.28 billion dollars in 2017. A dollar of subsidy to small business lending increases small business lending by \$79. Thus, in the context of the model, when the U.S. Small Business Administration provides subsidized loans and loan guarantees to small businesses for start-up and expansion, risky small businesses become much less financially constrained.

In the second policy experiment, I subsidize small banks (with total loans of less than \$100 million) with 1% of their loan amounts in order to reduce their exit rate. This policy targets at the crowding-out effect. In comparison with the benchmark model, this policy does not increase relationship loans. This is because this policy gives small banks an incentive to grow. When these small banks grow, they reduce their share of relationship loans to small businesses. This policy costs \$796 million in 2017 without an increase in small business lending. A dollar of subsidy to small banks increases small business lending by \$0. Berger et al. (2005) suggests that instead of subsidizing small business lending directly, we should subsidize the intermediaries that have a comparative advantage in relationship lending. My study shows that if we do not consider the general effects and the substitution effects, this policy will increase lending to small business loans by \$10 for \$1 subsidy of \$100 to small banks' loans. However, when we consider these two effects, this policy does not have any effect on lending to small business loans.

In the last policy experiment, I decrease small banks' costs of staying by 1% (small banks: banks with loans of less than \$100 million). This experiment is to see whether lending to small businesses will increase if policy decreases small banks' regulatory burden. I find that lending to small businesses in 2017 increases from \$322 to \$343 billion under this policy. This policy costs \$10,475 billion. Therefore, \$1 of decrease in banks' regulatory burden increases small business lending by \$0.002.

6 Conclusions, Implications and Future work

I study the effects of IT improvements on small business lending in a quantitative structural framework. The framework includes a dynamic model of relationship banking, an estimation that quantifies the advancement of IT improvements in the banking market, and an evaluation of policies that may encourage lending to small businesses. The model does a reasonable job of explaining some key features of the U.S. commercial banking market: the increasing market concentration, the exit of small banks, and the difference in the share of small business loans among large and small banks. The model shows that when the data processing costs per loan dollar decline by 2.5% annually, lending to small businesses declines 1% annually. This decline may lead to an annual loss of 50,000 jobs according to Chen, Hanson and Stein (2017). The findings in this paper add insight to the debate over how to encourage lending to small businesses. They imply that policy should subsidize small risky borrowers, not small banks, even though small banks may have a comparative advantage in relationship lending. This research also implies that even if the repeal of Dodd-Frank Act can decrease the regulatory burden on banks, lending to small businesses may increase little.

Conducting a welfare analysis of the reallocation of bank loans from small to large firms can be very interesting and meaningful; however, it will complicate the model too much and is away from the focus of this paper. I will address this question in my next paper, in which we study how the reallocation of bank lending can increase the monopsony power in local labor market and therefore, decrease workers' wage income.

Reference

- Aghion, Philippe, and Peter Howitt.** 1990. "A model of growth through creative destruction." National Bureau of Economic Research.
- Azar, José, Ioana Marinescu, and Marshall I Steinbaum.** 2017. "Labor market concentration." National Bureau of Economic Research.
- Baumol, William J.** 1968. "Entrepreneurship in Economic Theory." *The American Economic Review*, 58(2): 64–71.
- Bazdresch, Santiago, R. Jay Kahn, and Toni M. Whited.** 2018. "Estimating and Testing Dynamic Corporate Finance Models." *The Review of Financial Studies*, 31(1): 322–361.
- Berger, Allen N.** 2003. "The economic effects of technological progress: Evidence from the banking industry." *Journal of Money, credit, and Banking*, 35(2): 141–176.
- Berger, Allen N, and Gregory F Udell.** 1995. "Relationship lending and lines of credit in small firm finance." *Journal of business*, 351–381.
- Berger, Allen N, and Gregory F Udell.** 2002. "Small business credit availability and relationship lending: The importance of bank organisational structure." *The economic journal*, 112(477).
- Berger, Allen N, and Robert DeYoung.** 2006. "Technological Progress and the Geographic Expansion of the Banking Industry." *Journal of Money, Credit, and Banking*, 38(6): 1483–1513.
- Berger, Allen N, Anthony Saunders, Joseph M Scalise, and Gregory F Udell.** 1998. "The effects of bank mergers and acquisitions on small business lending." *Journal of financial Economics*, 50(2): 187–229.
- Berger, Allen N, Christa HS Bouwman, and Dasol Kim.** 2017. "Small bank comparative advantages in alleviating financial constraints and providing liquidity insurance over time." *The Review of Financial Studies*, 30(10): 3416–3454.
- Berger, Allen N, Nathan H Miller, Mitchell A Petersen, Raghuram G Rajan, and Jeremy C Stein.** 2005. "Does function follow organizational form? Evidence

- from the lending practices of large and small banks.” *Journal of Financial economics*, 76(2): 237–269.
- Berger, Allen N, Richard J Rosen, and Gregory F Udell.** 2007. “Does market size structure affect competition? The case of small business lending.” *Journal of Banking & Finance*, 31(1): 11–33.
- Berger, Allen N, W Scott Frame, and Nathan H Miller.** 2005. “Credit scoring and the availability, price, and risk of small business credit.” *Journal of money, credit and banking*, 191–222.
- Bernanke, Ben S, Mark Gertler, and Simon Gilchrist.** 1999. “The financial accelerator in a quantitative business cycle framework.” *Handbook of macroeconomics*, 1: 1341–1393.
- Bharath, Sreedhar T, Sandeep Dahiya, Anthony Saunders, and Anand Srinivasan.** 2009. “Lending relationships and loan contract terms.” *The Review of Financial Studies*, 24(4): 1141–1203.
- Birch, David L.** 1979. *The job generation process*. Cambridge, Mass. : M.I.T. Program on Neighborhood and Regional Change.
- Black, Sandra E., and Philip E. Strahan.** 2002. “Entrepreneurship and Bank Credit Availability.” *The Journal of Finance*, 57(6): 2807–2833.
- Bloom, Nicholas, Max Floetotto, Nir Jaimovich, Itay Saporta-Eksten, and Stephen J Terry.** 2012. “Really uncertain business cycles.” National Bureau of Economic Research.
- Bolton, Patrick, Xavier Freixas, Leonardo Gambacorta, and Paolo Emilio Mistruilli.** 2016. “Relationship and transaction lending in a crisis.” *The Review of Financial Studies*, 29(10): 2643–2676.
- Boot, Arnoud WA, and Anjan V Thakor.** 2000. “Can relationship banking survive competition?” *The journal of Finance*, 55(2): 679–713.
- Bordo, Michael D., and John V. Duca.** 2018. “The Impact of the Dodd-Frank Act on Small Business.” *No. w24501. National Bureau of Economic Research*.
- Brown, J David, John S Earle, and Yana Morgulis.** 2015. “Job creation, small vs. large vs. young, and the SBA.” National Bureau of Economic Research.

- Campello, Murillo, John R Graham, and Campbell R Harvey.** 2010. “The real effects of financial constraints: Evidence from a financial crisis.” *Journal of financial Economics*, 97(3): 470–487.
- Chen, Brian S, Samuel G Hanson, and Jeremy C Stein.** 2017. “The decline of big-bank lending to small business: Dynamic impacts on local credit and labor markets.”
- Chen, Joseph, Harrison Hong, Ming Huang, and Jeffrey D Kubik.** 2004. “Does fund size erode mutual fund performance? The role of liquidity and organization.” *The American Economic Review*, 94(5): 1276–1302.
- Chodorow-Reich, Gabriel.** 2013. “The employment effects of credit market disruptions: Firm-level evidence from the 2008–9 financial crisis.” *The Quarterly Journal of Economics*, 129(1): 1–59.
- Cole, Rebel A, Lawrence G Goldberg, and Lawrence J White.** 2004. “Cookie cutter vs. character: The micro structure of small business lending by large and small banks.” *Journal of financial and quantitative analysis*, 39(2): 227–251.
- Corbae, Dean, Pablo Dâerasmo, et al.** 2011. “A quantitative model of banking industry dynamics.”
- Cortés, Kristle, Yuliya Demyanyk, Lei Li, Elena Loutskina, and Philip E Strahan.** 2018. “Stress Tests and Small Business Lending.” National Bureau of Economic Research.
- Edmiston, Kelly D.** 2007. “The role of small and large businesses in economic development.”
- Evans, David S., and Boyan Jovanovic.** 1989. “An Estimated Model of Entrepreneurial Choice under Liquidity Constraints.” *Journal of Political Economy*, 97(4): 808–827.
- Gennaioli, Nicola, Andrei Shleifer, and Robert Vishny.** 2012. “Neglected risks, financial innovation, and financial fragility.” *Journal of Financial Economics*, 104(3): 452–468.
- Gertler, Mark, and Simon Gilchrist.** 1994. “Monetary policy, business cycles, and the behavior of small manufacturing firms.” *The Quarterly Journal of Economics*, 109(2): 309–340.

- Greenwood, Jeremy, and Boyan Jovanovic.** 1990. “Financial development, growth, and the distribution of income.” *Journal of political Economy*, 98(5, Part 1): 1076–1107.
- Hayashi, Fumiko, Bin Grace Li, and Zhu Wang.** 2017. “Innovation, Deregulation, and the Life Cycle of a Financial Service Industry.” *Review of Economic Dynamics*, 26: 180–203.
- Hopenhayn, Hugo A.** 1992. “Entry, exit, and firm dynamics in long run equilibrium.” *Econometrica: Journal of the Econometric Society*, 1127–1150.
- Hopenhayn, Hugo Andrés.** 1993. “The shakeout.”
- Keeton, William R.** 1996. “Do bank mergers reduce lending to businesses and farmers? New evidence from tenth district states.” *Economic Review-Federal Reserve Bank of Kansas City*, 81(3): 63.
- King, Robert G, and Ross Levine.** 1993. “Finance and growth: Schumpeter might be right.” *The quarterly journal of economics*, 108(3): 717–737.
- Krusell, Per, and Anthony A Smith, Jr.** 1998. “Income and wealth heterogeneity in the macroeconomy.” *Journal of political Economy*, 106(5): 867–896.
- Liberti, Jose M, and Atif R Mian.** 2009. “Estimating the effect of hierarchies on information use.” *The Review of Financial Studies*, 22(10): 4057–4090.
- Liberti, José María, and Mitchell A Petersen.** 2017. “Information: Hard and soft.” *Rev. Corporate Finance Stud.*
- Mills, Karen, and Brayden McCarthy.** 2016. “The State of Small Business Lending: Innovation and Technology and the Implications for Regulation.”
- Myler, Larry.** 2015. “Face Interactions Can Never Be Replaced By Technology.” <https://www.forbes.com/sites/larrymyler/2015/11/21/>.
- Nadiri, M Ishaq, and Ingmar R Prucha.** 1996. “Estimation of the depreciation rate of physical and R&D capital in the US total manufacturing sector.” *Economic Inquiry*, 34(1): 43–56.
- Nguyen, Hoai-Luu Q.** 2014. “Do bank branches still matter? The effect of closings on local economic outcomes.”

- OECD.** 2014. *Financing SMEs and Entrepreneurs 2014*.
- Peek, Joe, and Eric S Rosengren.** 1995. “Small business credit availability: How important is size of lender?”
- Petersen, Mitchell A.** 2004. “Information: Hard and soft.”
- Petersen, Mitchell A, and Raghuram G Rajan.** 1994. “The benefits of lending relationships: Evidence from small business data.” *The journal of finance*, 49(1): 3–37.
- Rajan, Raghuram G.** 1992. “Insiders and outsiders: The choice between informed and arm’s-length debt.” *The Journal of Finance*, 47(4): 1367–1400.
- Rajan, Raghuram G.** 2006. “Has finance made the world riskier?” *European Financial Management*, 12(4): 499–533.
- Romer, Paul M.** 1990. “Endogenous technological change.” *Journal of political Economy*, 98(5, Part 2): S71–S102.
- Stein, Jeremy C.** 2002. “Information production and capital allocation: Decentralized versus hierarchical firms.” *The journal of finance*, 57(5): 1891–1921.
- Stiglitz, Joseph E.** 2000. “Capital market liberalization, economic growth, and instability.” *World development*, 28(6): 1075–1086.
- Strahan, Philip E, and James P Weston.** 1998. “Small business lending and the changing structure of the banking industry.” *Journal of Banking & Finance*, 22(6): 821–845.
- Sullivan, Richard J, and Zhu Wang.** 2013. “Internet Banking: An Exploration in Technology Diffusion and Impact.”
- Sullivan, Richard, Zhu Wang, et al.** 2005. “Internet banking: An exploration in technology diffusion and impact.” *Federal Reserve Bank of Kansas City Payments System Research Working Paper*, 05–05.
- Townsend, Robert M.** 1979. “Optimal contracts and competitive markets with costly state verification.” *Journal of Economic theory*, 21(2): 265–293.
- Triplett, and Bosworth.** July 2002. “‘Baumol’s Disease’ has been cured: It and multi-factor productivity in us services industries.” *Brookings Institution working paper*.

Von Thadden, Ernst-Ludwig. 1995. "Long-term contracts, short-term investment and monitoring." *The Review of Economic Studies*, 62(4): 557–575.

A Mathematical Appendix

A.1 Proof of Theorem 1

The bank with assets z solves:

$$\max_{I_j, I_j^S} \{m(z) \left(\int_{\theta^*}^{\theta^{**}} ((1-\theta)R_H + \theta R_R - r) d\theta + \int_0^{\theta^*} ((1-\theta)R_H + \theta R_L - r) d\theta \right) - L^S c(L^S)\}$$

where $L^S = m(z)(\theta^{**} - \theta^*)$, $c(L^S) = \frac{1}{F(\omega+1)}(L^S)^\omega$

Take the first order conditions of θ^{**}, θ^* :

$$F((1 - \theta^{**})R_H + \theta^{**}(R_R - r) = [m(z)(\theta^{**} - \theta^*)]^\omega \quad (\text{A.1})$$

$$F\theta^* R_R = [m(z)(\theta^{**} - \theta^*)]^\omega \quad (\text{A.2})$$

Solve θ^{**} from equation (6),

$$\theta^{**} = \theta^* + \frac{1}{m(z)} [F\theta^* R_R]^{1/\omega} \quad (\text{A.3})$$

From (5) and (6):

$$\theta^* R_R = (1 - \theta^{**})R_H + \theta^{**} R_R - r \quad (\text{A.4})$$

Take (7) into (8),

$$\theta^*(R_H - R_L) = R_H - \frac{1}{m(z)} [F(1 - \theta^*)R_R]^{1/\omega} (R_H - R_L - R_R) - r \quad (\text{A.5})$$

from (9) we see that when z increases, θ^* is larger. Similarly, I solve θ^{**} and I find that when z increases, θ^{**} is smaller.

A.2 Model Computation

Banks' choice of relationship and transaction loans in each period is a static problem. In the first step, I compute banks' choice of relationship loans and transaction loans at the assumed deposit interest rate. In the second step, I compute the deposit interest rate that clears the deposit market. In the third step, I update the deposit interest rate and in the last step, I iterate steps 1-3 until the deposit interest rates converge.

The computation of dynamic programming takes four steps. In the first step, I compute banks' value function at the initial assumed deposit interest rate, $\{r_t\}_{t=1,2,\dots}$. I apply the contraction mapping theorem. I start by making an initial guess about the value function at each assets point (an initial guess of zero at each point). I compute the first iteration of the value function by considering the future value as the initial guess. This will yield a new value (the sum of the current payoff and the discounted (expected) future payoff). I use this value as the future value in the next iteration to produce a new value, etc.⁸ In the

⁸ The computation of value function is referred to http://home.uchicago.edu/hickmanbr/uploads/chapter5_2.pdf

second step, I solve banks' problems and compute the deposit interest rate that clears the deposit market in each period. In the third step, I update the deposit interest rates, $\{r_t\}_{t=1,2,\dots}$, and in the last step, I iterate step 1-3 until the deposit interest rates converge.

B Tables

Table.1. Firm Age, Loan Approval Rates and Net Jobs Created

This table shows the relationship between firm ages, firms' loan approval rates and the net jobs created with one million dollars of bank loans. In the table, firms younger than 2 years old can create the most net new jobs with \$1 million of bank loans; however, they have the least loan approval rates. Data Source: 2014 Annual Survey of Entrepreneurs, U.S. Census Bureau and Brown, Earle and Morgulis (2015).

Age	Approval Rates (%)	Net Jobs Created with \$1 Million of Loans
<2	61.5	3.13–5.34
2-3	65.7	3.13
4-5	69.3	2.96
6-10	72	2.96
11-15	79.3	3.02
>16	84.9	3.02

Table. 2. Definitions of Variables

The table shows how I measure the model variables in the data. I use net total loans and leases in the data to measure the variable of total loans in the model. I use commercial and industrial loans less than \$1 million dollars in the data (i.e. small business loans) to measure the variable of relationship loans in the model. I use sum of loans past due, unaccrual and charged-off to net total loans and leases in the data to measure the variable of delinquency rate in the model.

Definitions in the Data	Variables in the Model
net total loans and leases	total loans
commercial and industrial loans less than 1 million dollars	relationship loans
sum of loans past due, unaccrual and charged off/net total loans and leases	delinquency rate

Table. 3. Summary of Statistics

The table shows the summary of statistics. In the paper, I only use the data of banks that have small business loans. Most US commercial banks have lending to small businesses. Very specialized banks may not issue loans to small businesses. I also exclude data from 2008 to 2011, which is the Great Recession. All the numbers are in millions of constant 2017 U.S. dollar. I use total loans and leases in the data to measure total loans. I use commercial and industrial loans less than \$1 million dollars in the data to measure small business loans. I use sum of loans past due, unaccrual and charged-off as delinquent loans.

2002-2007, 2012-2017, No.of banks= 78,190				
Variables	Mean	Std	Min	Max
total loans	1,052	16,800	9	940,000
small businesses loans	47	447	0	29,800
delinquent loans	31	759	0	82,300
total interest and fee income on loans	37	593	0	38,400

Table 4. Values of Parameters and Targeted Moments

This table shows the values for each estimated parameter and the moments that used to identify the values of each parameter. The sample period is 2002-2017, excluding 2008-2011, with 78,190 banks. Estimation is done with the simulated method of moments. The standard errors are calculated using the method from Bazdresch, Kahn and Whited (2018) (in parentheses). I choose structural model parameters by matching the moments from the dynamic general equilibrium model to the corresponding moments from these data. The model is solved by value-function iteration. The estimation is to identify the parameters in a bank's technology for evaluating borrowers' delinquency rates, M_0, λ, α , the parameters in a bank's technology for building relationships, F, ω , the parameters in the deposit supply function, n_r , the parameters in the technology used by banks to accumulate assets, δ_z, A, γ , the distribution of the staying costs, μ, σ , the parameters that characterize the returns from the projects, R_L, R_R , and the parameters that characterize the asset distribution of newly entered banks, μ_z, σ_z . I estimate period 0 in the model to the year of 2002. In the first period, incumbent banks have assets z that are from the distribution of $\log - \text{gamma}(\mu_0, \sigma_0)$.

Parameter	Description	Value	Moments
M_0		1,339	total loans of large and small banks
	parameters in the technology	(0.80)	
α	of evaluating borrowers' credit	.89	market concentration
		(0.0003)	
F		148	
	parameters in the technology	(0.1)	small business loans:
ω	of building relationships	.0279	shares and amounts in each year
		(0.00005)	
R_L	liquidation value	.34	share of small business loans
		(0.0001)	
R_R	return from restructured debt	.553	delinquency rates
		(0.0002)	
λ	measure of technological improvement	.0365	annual loan growth rates
		(0.00007)	
γ		.31	
	parameter in assets	(0.0013)	
A	accumulation technology	.36	market concentration
		(0.0002)	
μ	mean of the log of the staying costs	5	
		(0.013)	
σ	std of of the log of the staying costs	7.8	probability of being a small bank
		(0.0008)	
μ_z	mean of the log of assets of new born banks	27.5	mean of loans of new born banks
		(0.037)	
σ_z	std of the log of assets of new born banks	.3	std of of loans of new born banks
		(0.0002)	
μ_0		21	total loans: mean
		(0.021)	
σ_0	log of assets of incumbent banks	.4	total loans: std
		(0.0008)	
n_r	parameter in deposit supply function	.152	delinquency rates
		(0.00007)	

Table. 5. Moments Comparison I

The table shows the results when I change the values of some parameters. In the baseline model, $M_0 = 1,339$, $\alpha = .89$, $\mu_0 = 21$, $\sigma_0 = .4$. In the table, the ratio of loan standard variation to total loans, is defined as $r_{1,t}$ and the ratio of average loans of large banks (banks in the top 25%) to the average loans of small banks (banks in the bottom 25%), is defined as $r_{2,t}$, where $t = 1, \dots, 12$.

Parameter	$\frac{r_{1,12}}{r_{1,1}}$	$\frac{r_{2,12}}{r_{2,1}}$
$M_0 = 1,636$.94	.96
$\alpha = .9$.5	.88
$\mu_0 = 21.2$	1.11	1.17
$\sigma_0 = .42$	1.1	1.08
baseline	1.14	1.09

Table. 6. Moments Comparison II

The table shows the results when I change the values of some parameters. In the baseline model, $F = 148$, $\omega = .0279$, $R_R = .553$, $n_r = .152$. In the table, the delinquency rate, the number of small banks, and the loan share of large banks are the average of these moments for each year. Small banks are banks with loans totaling less than \$100 million dollars, and large banks are banks with loans totaling more than \$1 billion.

Parameter	Delinquency Rate	Number of Small Banks	Loan Share of Large Banks
$F = 181$.0208	3,541	80.7%
$\omega = .0259$.0227	3,224	81.3%
$R_R = .56$.0226	2,771	84.3%
$n_r = .15$.0233	2,514	80.9%
baseline	.023	2,790	80.8%

Table. 7. Moments Comparison III

The table shows the results when I change the values of some parameters. In the baseline model, $\lambda = .0365$, $\gamma = .31$, $A = .36$. In the table, the ratio of loan standard variation to total loans, is defined as $r_{1,t}$ and the ratio of average loans of large banks (banks in the top 25%) to the average loans of small banks (banks in the bottom 25%), is defined as $r_{2,t}$, where $t = 1, \dots, 12$.

Parameter	$\frac{r_{1,12}}{r_{1,1}}$	$\frac{r_{2,12}}{r_{2,1}}$
$\lambda = .043$.72	1.03
$\gamma = .29$	1.18	1.12
$A = .38$	1.13	1.16
baseline	1.14	1.09

Table. 8. Policy Comparisons

In the table, I compare the effects from different policies, including the increase in dollar amount of small business loans, the delinquency rates and the policy effects without general equilibrium effects or substitution effects. In the first policy, I subsidize small banks with loans less than \$100 million. In the second policy, I reduce the staying costs of small banks with loans less than \$100 million. In the last policy, I subsidize loans to borrowers with delinquency rates equal to or greater than 5%. In the data, these loans are small business loans.

\$1 Subsidy of \$100 to	Increase in Small Business Lending	Delinquency Rate	No Substitution or GE Effect
small banks	\$0	2.29%	\$10
small banks' staying costs	0.2 cents	2.28%	0.02 cents
loans with delinquency rates $\geq 5\%$	\$79	2.34%	